



IN-LINE DUCT FAN

ILHT Series - F400 120 rated centrifugal fans



Officially approved to EN12101-3



CONTINUOUS operation

Range of direct-drive rectangular in-line fans designed for smoke extraction in fire conditions and certified **F400 120** (CE marked). All models are suitable for air stream temperature up to 80°C. The casings are manufactured from high grade robust **galvanised sheet steel**. Due to the flexible design and configuration the ILHT units can be installed in any position both horizontal or vertical. All fans incorporate a centrifugal backward curved impeller manufactured from galvanized sheet steel. Available, depending upon the model, with three phase motors in 4, 6, 8, 4/6, 4/8, 6/8 or 6/12 poles.

Motors

All the motors are **IP55, Class F** insulation.

Electrical supply:

Three phase 230/ 400V-50Hz, 1-speed motors.

Three phase 400V-50Hz, 2-speed motors.

(See characteristics chart).

On request

Single phase motors.

Speed controllable motor by voltage.

Double thickness (double skin) panels internally lined with sound and thermal fibre glass insulation (25 mm).

Easy to install



Fixings fitted to ease the installation

APPLICATIONS



Commercial and industrial kitchens

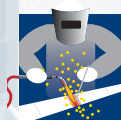

Welding installations



F400-120



80°C

CONTINUOUS operation

VERSATILE DESIGN

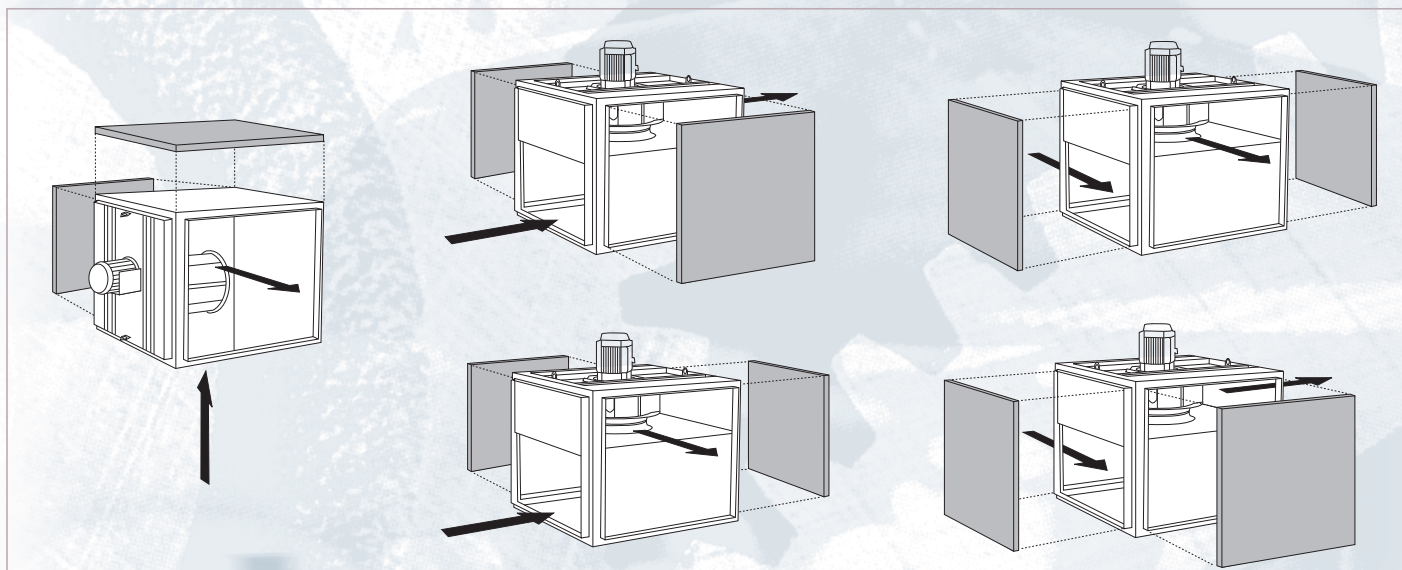

Interchangeable side panels, to produce the different possibilities of air extraction and supply.

■ Technical characteristics

Before installation check that the product electrical characteristics listed on the data plate label (Voltage, power, frequency etc) match those of the intended electrical supply.

Model	Speed (r.p.m.)	Maximum absorbed power (kW)	Maximum absorbed current (A) 400 V	Speed (r.p.m.)	Motor power (kW)	Maximum absorbed current (A) 400 V	Maximum air volume m ³ /h	Sound pressure level dB(A)*
4 POLES - 1 SPEED								
ILHT/4-035	1415	0,55	1,4				3500	56
ILHT/4-050	1415	0,75	1,7				5000	59
ILHT/4-060	1420	1,5	3,2				7000	62
ILHT/4-065	1430	2,2	4,6				10000	64
6 POLES - 1 SPEED								
ILHT/6-035	940	0,25	1,0				2333	50
ILHT/6-050	940	0,25	1,0				3333	51
ILHT/6-060	940	0,37	1,2				4667	53
ILHT/6-065	930	0,75	2,0				6667	56
ILHT/6-085	950	1,1	2,8				8400	58
ILHT/6-110	940	2,2	5,4				12500	60
ILHT/6-140	960	3	6,8				15000	63
ILHT/6-190	955	5,5	12,2				19000	64
8 POLES - 1 SPEED								
ILHT/8-065	700	0,37	1,4				5000	49
ILHT/8-085	700	0,55	1,9				6300	52
ILHT/8-110	700	1,1	3,4				9375	54
ILHT/8-140	695	1,5	4,0				11250	57
ILHT/8-190	720	3	7,2				14250	58
4/6 POLES - 2 SPEED								
ILHT/4/6-050	1415	0,75	2,0	940	0,25	1,3	5000	59
ILHT/4/6-060	1420	1,5	3,7	940	0,37	1,7	7000	62
ILHT/4/6-065	1445	3	6,8	975	1	4,1	10000	64
4/8 POLES - 2 SPEED								
ILHT/4/8-035	1360	0,6	1,9	690	0,15	0,9	3500	56
ILHT/4/8-050	1380	0,8	2,0	690	0,2	1,0	5000	59
ILHT/4/8-060	1390	1,6	4,1	700	0,4	1,8	7000	62
ILHT/4/8-065	1415	2,8	6,1	715	0,7	2,4	10000	64
6/8 POLES - 2 SPEED								
ILHT/6/8-035	940	0,55	2,1	700	0,14	1,2	2333	50
ILHT/6/8-050	940	0,55	2,1	700	0,14	1,2	3333	51
ILHT/6/8-060	930	0,55	2,1	690	0,14	1,2	4667	53
ILHT/6/8-065	950	1,1	3,6	720	0,55	2,5	6667	56
ILHT/6/8-085	965	1,1	3,6	720	0,55	2,5	8400	58
ILHT/6/8-110	985	3,0	8,0	725	0,75	3,8	12500	60
ILHT/6/8-140	960	4,0	11,3	695	1,1	4,8	15000	63
6/12 POLES - 2 SPEED								
ILHT/6/12-110	950	4	12,6	470	1,0	5,1	12500	60
ILHT/6/12-140	950	4	12,6	470	1,0	5,1	15000	63
ILHT/6/12-190	975	5,5	14,1	480	1,1	5,4	19000	64

*Measured at 6 m from the inlet side.



■ Dimensions (mm)

Mounting with the motor in horizontal position

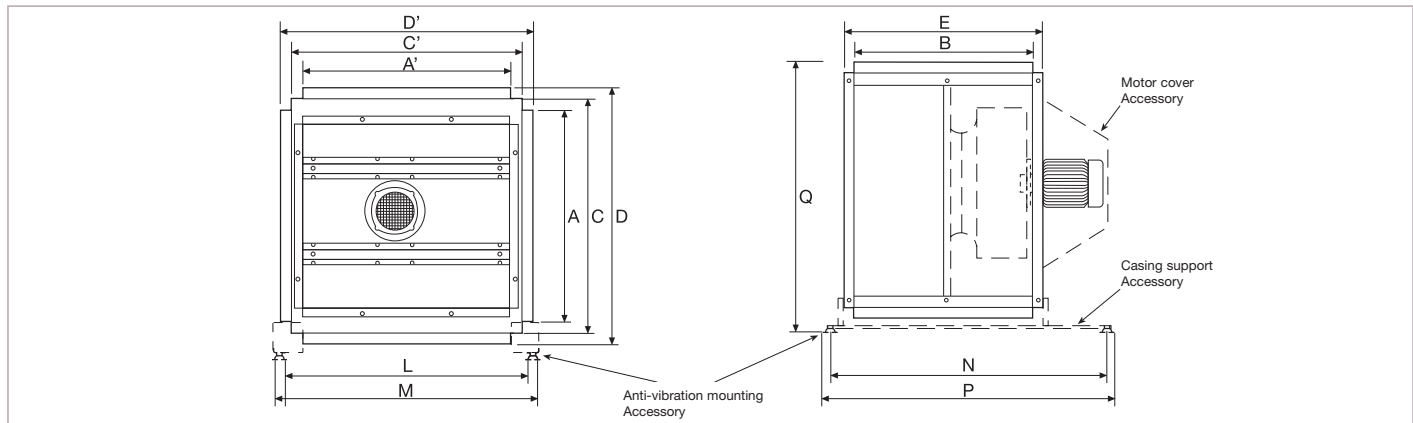

Model	A	B	C	D	E	L	M	N	P	Q	Weight (kg)
035	700	600	780	850	675	727	927	1038	1122	928	70
050	700	600	780	850	675	727	927	1038	1122	928	90
060	800	700	880	950	775	827	1027	1182	1266	1028	110
065	800	700	880	950	775	827	1027	1182	1266	1028	135
085	900	800	1015	1085	875	962	1162	1330	1414	1175	145
110	900	800	1015	1085	875	962	1162	1330	1414	1175	160
140	1000	900	1115	1185	975	1062	1262	1430	1514	1275	175
190	1100	1000	1215	1315	1075	1162	1362	1530	1614	1375	210

Mounting with the motor in vertical position

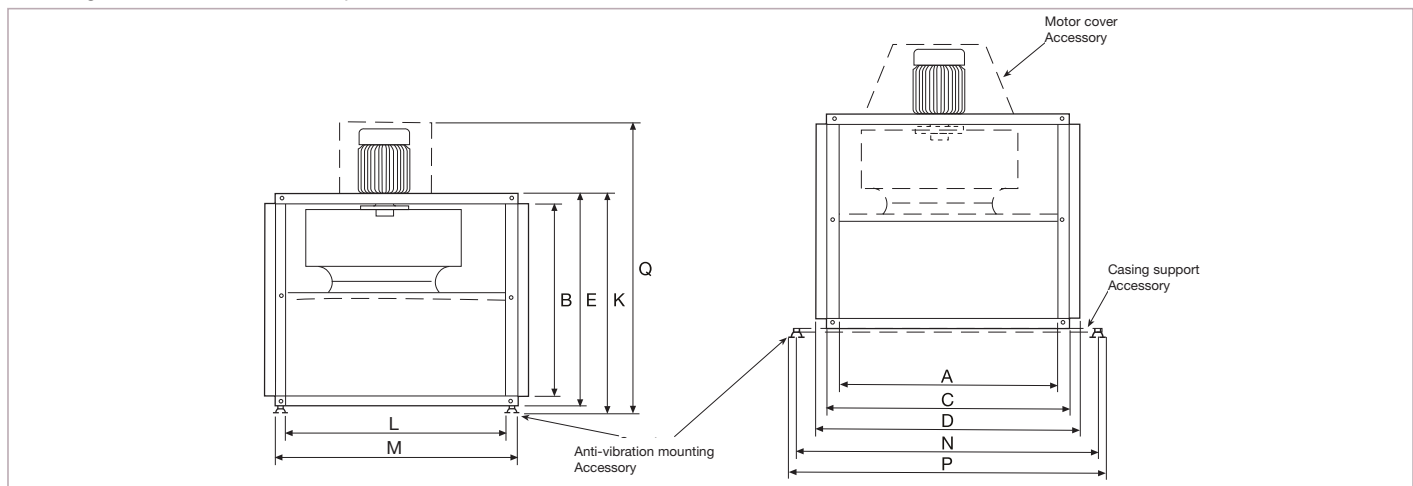

Model	A	B	C	D	E	K	L	M	N	P	Q	Weight (kg)
035	700	600	780	850	675	722	587	787	1038	1122	1005	70
050	700	600	780	850	675	722	587	787	1038	1122	1005	90
060	800	700	880	950	775	822	687	887	1182	1266	1155	110
065	800	700	880	950	775	822	687	887	1182	1266	1155	135
085	900	800	1015	1085	875	934	822	1022	1330	1414	1345	145
110	900	800	1015	1085	875	934	822	1022	1330	1414	1345	160
140	1000	900	1115	1185	975	1034	922	1122	1430	1514	1445	175
190	1100	1000	1215	1315	1075	1134	1022	1222	1530	1614	1545	210

Performance curves

- Q = Air volume in, m³/hr and m³/s.
- Pe = Static pressure in mmWG and Pa.
- Dry air at 20°C and 760 mmHg.
- Performance data in accordance with ISO 5801 and AMCA 210-99 Standards.

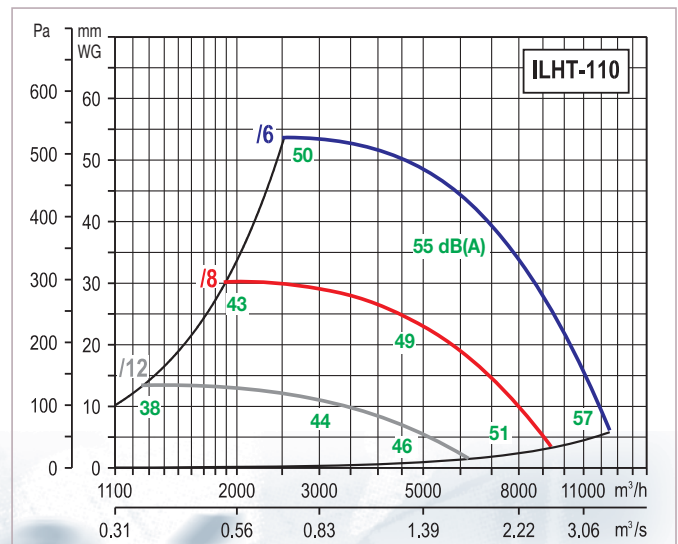
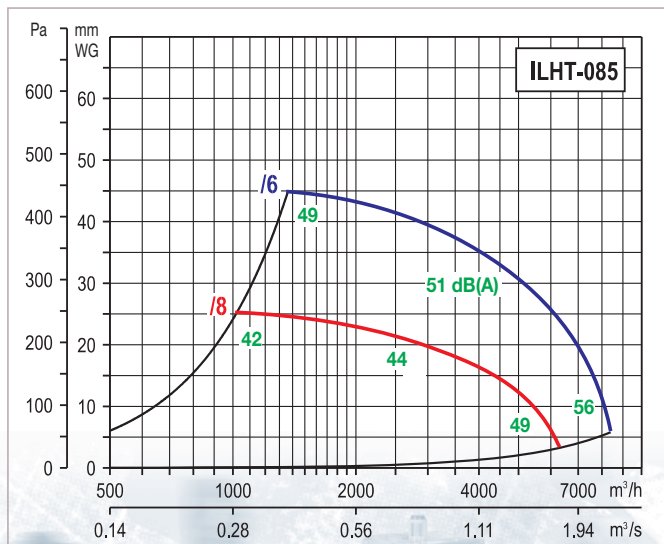
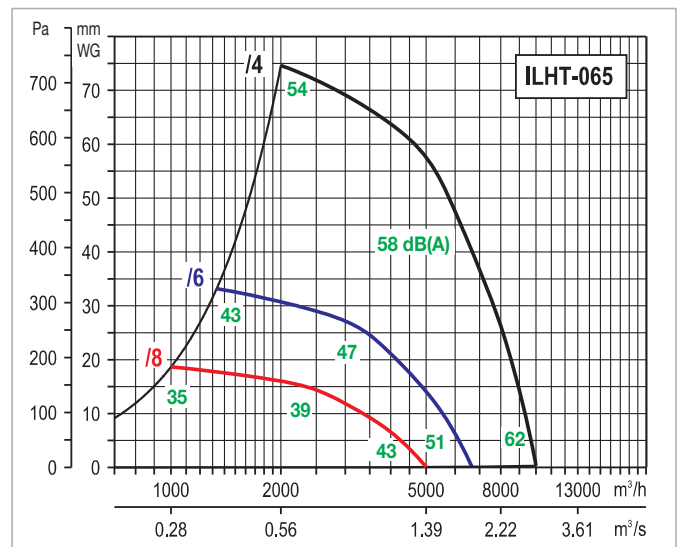
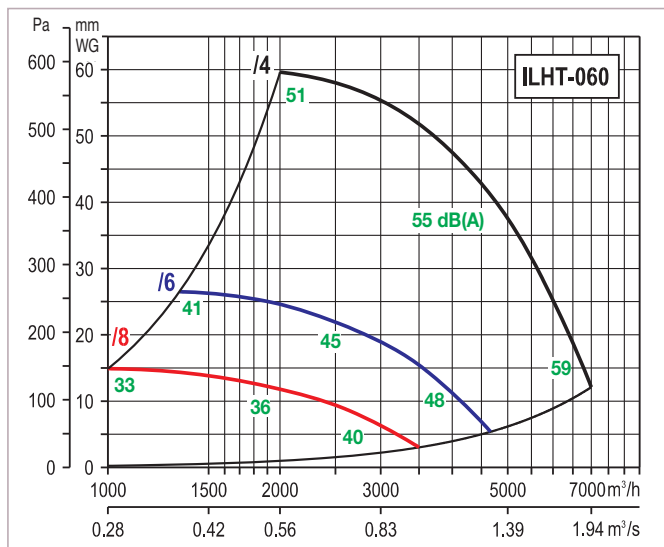
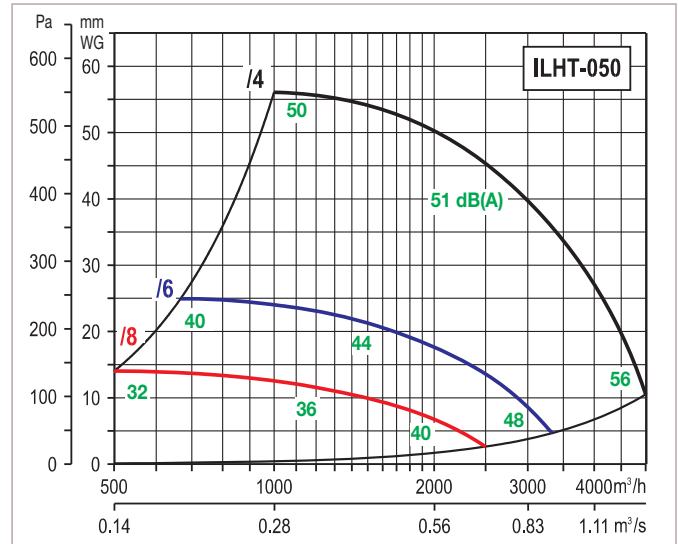
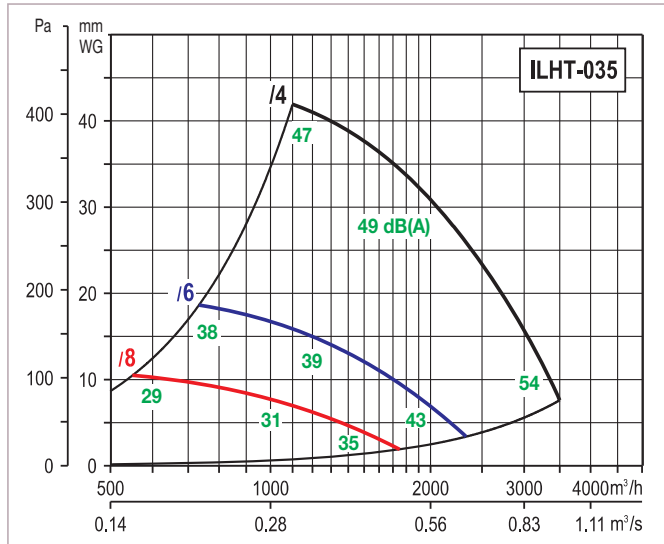

Pressure sound level measured at 6m distance with free ducted inlet and outlet.

Performance curves

- Q = Air volume in, m³/hr and m³/s.
- Pe = Static pressure in mmWG and Pa.
- Dry air at 20°C and 760 mmHg.
- Performance data in accordance with ISO 5801 and AMCA 210-99 Standards.

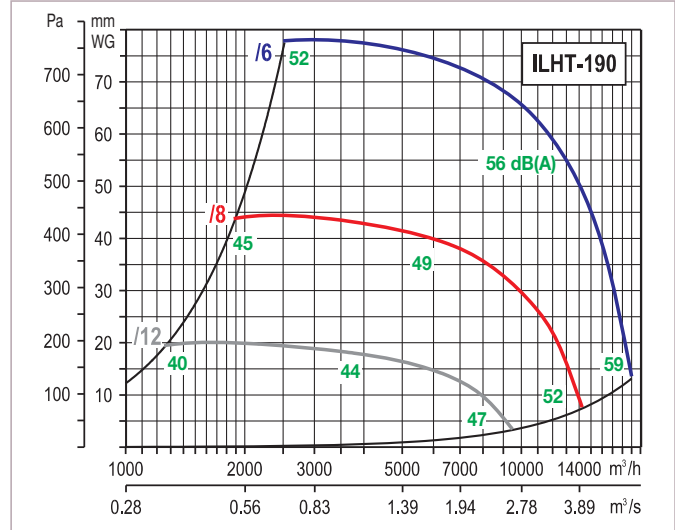
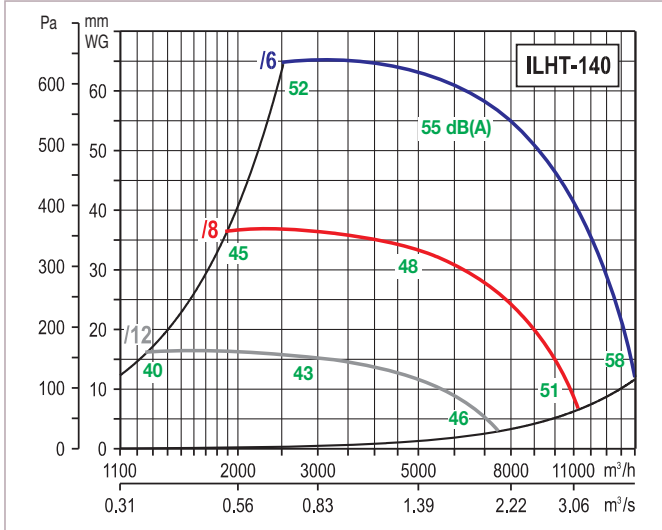

Pressure sound level measured at 6m distance with free ducted inlet and outlet.

Mounting accessories

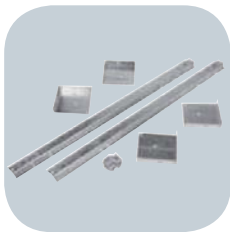

ILHT-SOPORTE
Mounting support

Model	Mounting support
035	ILHT-SOPORTE - 035
050	ILHT-SOPORTE - 035
060	ILHT-SOPORTE - 060
065	ILHT-SOPORTE - 060
085	ILHT-SOPORTE - 085
110	ILHT-SOPORTE - 085
140	ILHT-SOPORTE - 140
190	ILHT-SOPORTE - 190



ILHT-BRIDA
Rectangular duct connection flange

Model	Rectangular duct connection flange
035	ILHT-BRIDA - 035
050	ILHT-BRIDA - 035
060	ILHT-BRIDA - 060
065	ILHT-BRIDA - 060
085	ILHT-BRIDA - 085
110	ILHT-BRIDA - 085
140	ILHT-BRIDA - 140
190	ILHT-BRIDA - 190



ILHT-VISERA-V
Vertical mounted, discharge protection guard

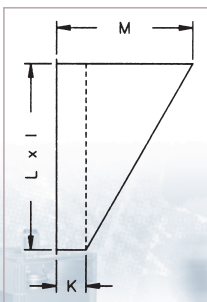

Model	Vertical protection guard	K	L	I	M
035	ILHT-VISERA-V - 035	140	605	705	490
050	ILHT-VISERA-V - 035	140	605	705	490
060	ILHT-VISERA-V - 060	140	705	805	550
065	ILHT-VISERA-V - 060	140	705	805	550
085	ILHT-VISERA-V - 085	140	806	906	605
110	ILHT-VISERA-V - 085	140	806	906	605
140	ILHT-VISERA-V - 140	140	906	1006	665
190	ILHT-VISERA-V - 190	140	1006	1106	725



ILHT-VISERA-H
Horizontal mounted, discharge protection guard

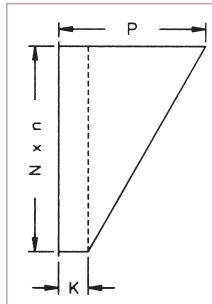

Model	Horizontal protection guard	K	N	n	P
035	ILHT-VISERA-H- 035	140	705	605	550
050	ILHT-VISERA-H- 035	140	705	605	550
060	ILHT-VISERA-H- 060	140	805	705	605
065	ILHT-VISERA-H- 060	140	805	705	605
085	ILHT-VISERA-H- 085	140	906	806	665
110	ILHT-VISERA-H- 085	140	906	806	665
140	ILHT-VISERA-H- 140	140	1006	906	725
190	ILHT-VISERA-H- 190	140	1106	1006	780



ILHT-ACOP-RECT
Flexible rectangular flanged duct connector

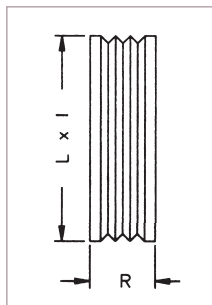

Model	Rectangular flexible connector	L	I	R
035	ILHT-ACOP-RECT- 700X600	605	705	160
050	ILHT-ACOP-RECT- 700X600	605	705	160
060	ILHT-ACOP-RECT- 800X700	705	805	160
065	ILHT-ACOP-RECT- 800X700	705	805	160
085	ILHT-ACOP-RECT- 900X800	806	906	160
110	ILHT-ACOP-RECT- 900X800	806	906	160
140	ILHT-ACOP-RECT- 1000X900	906	1006	160
190	ILHT-ACOP-RECT- 1100X1000	1006	1106	160



ILHT-TAPAMOTOR-V
Motor cover (for outdoor mounted installations)

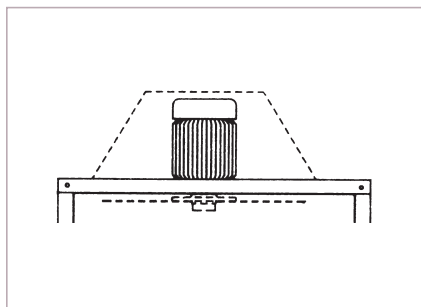

Model	Motor protection guards
035	ILHT-TAPA-MOTOR-V- 035
050	ILHT-TAPA-MOTOR-V- 035
060	ILHT-TAPA-MOTOR-V- 060
065	ILHT-TAPA-MOTOR-V- 060
085	ILHT-TAPA-MOTOR-V- 085
110	ILHT-TAPA-MOTOR-V- 085
140	ILHT-TAPA-MOTOR-V- 140
190	ILHT-TAPA-MOTOR-V- 140



ISA-ILHT
anti-vibrations support. (Set of 4 rubber supports)

■ Electrical accessories



INTZ
Disconnecting switch



DPS 2-30
DPS 10-100
Differential pressure switch



DEMA
Circuit breaker